

IF IN DOUBT, ASK.

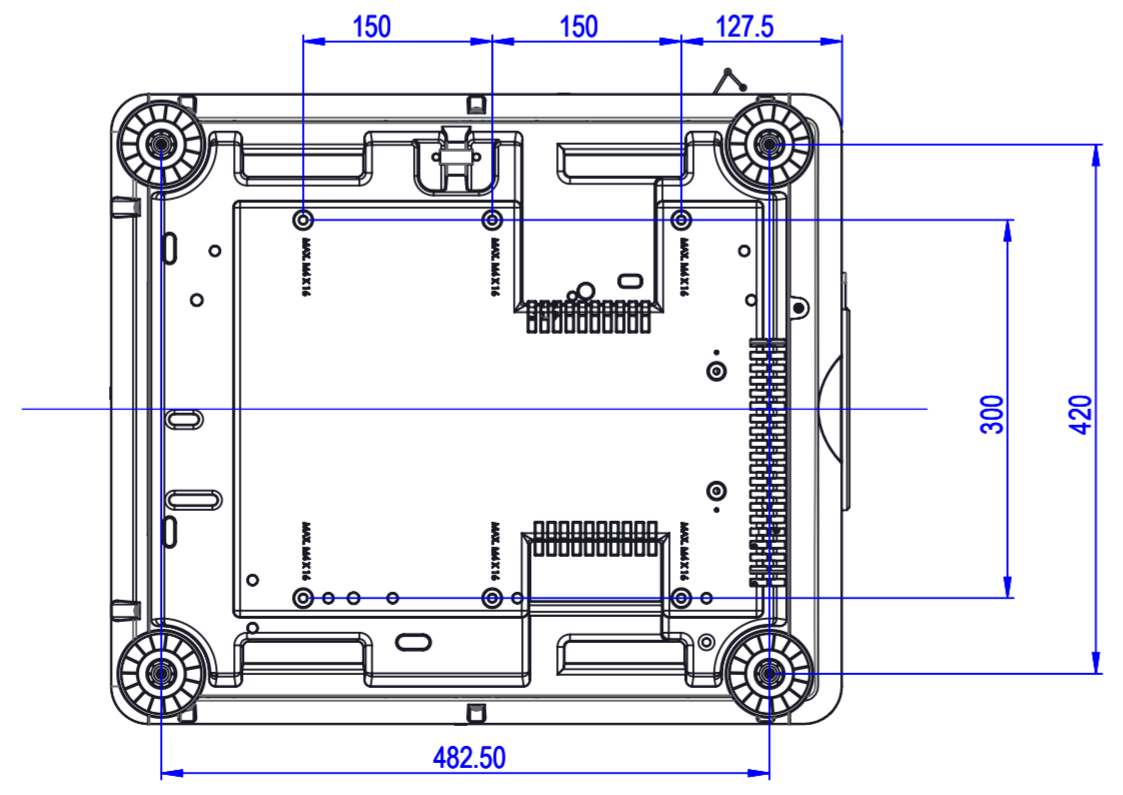
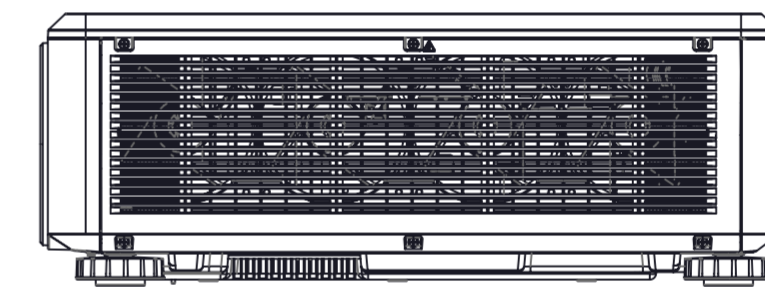
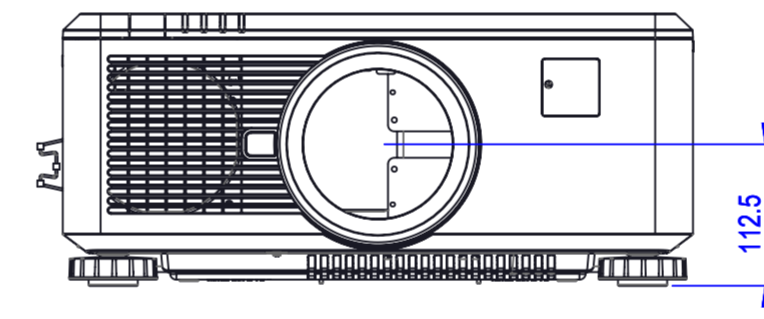
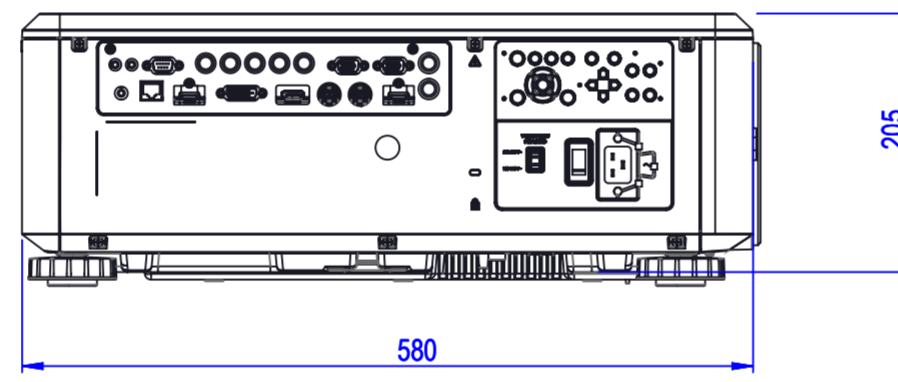
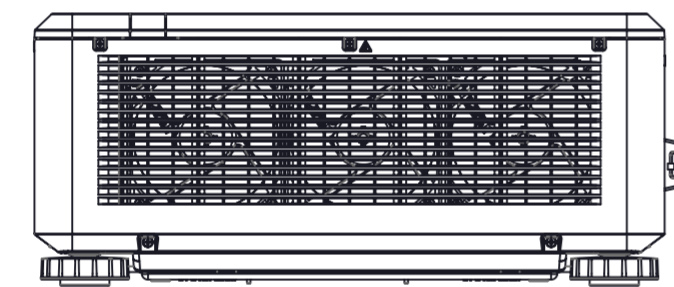
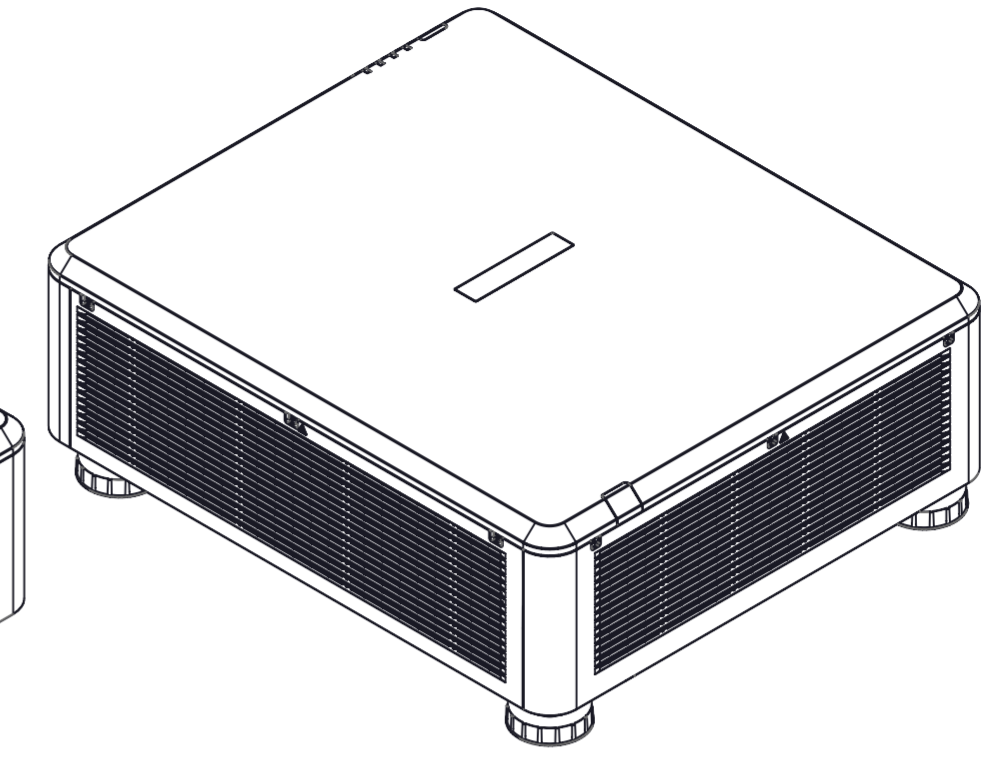
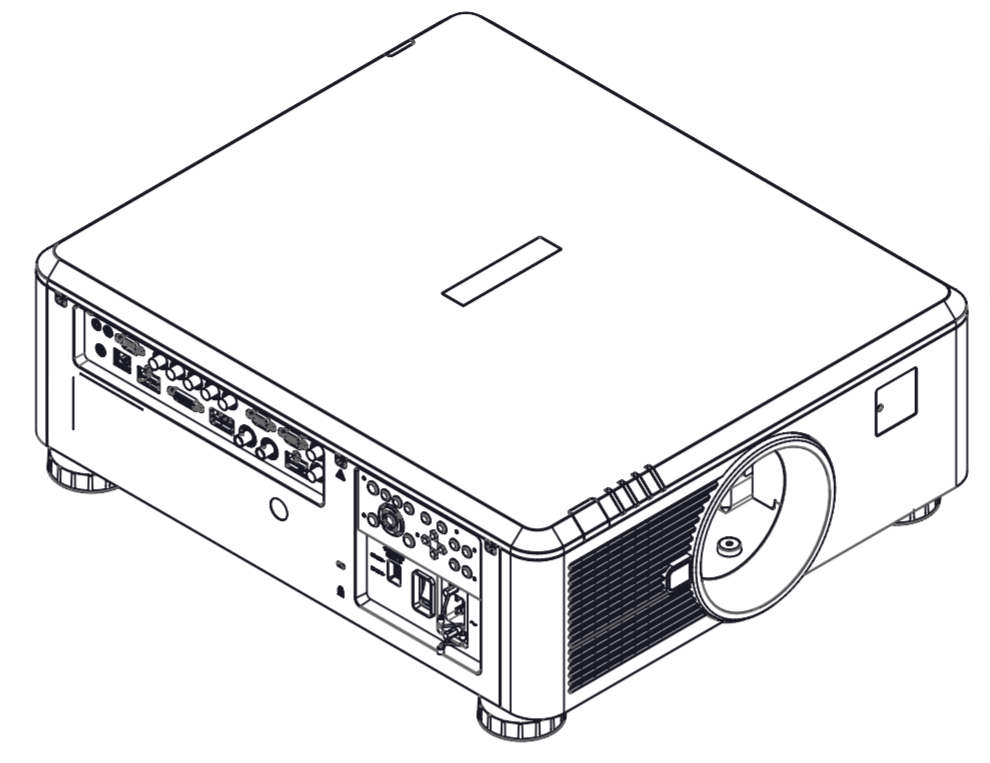
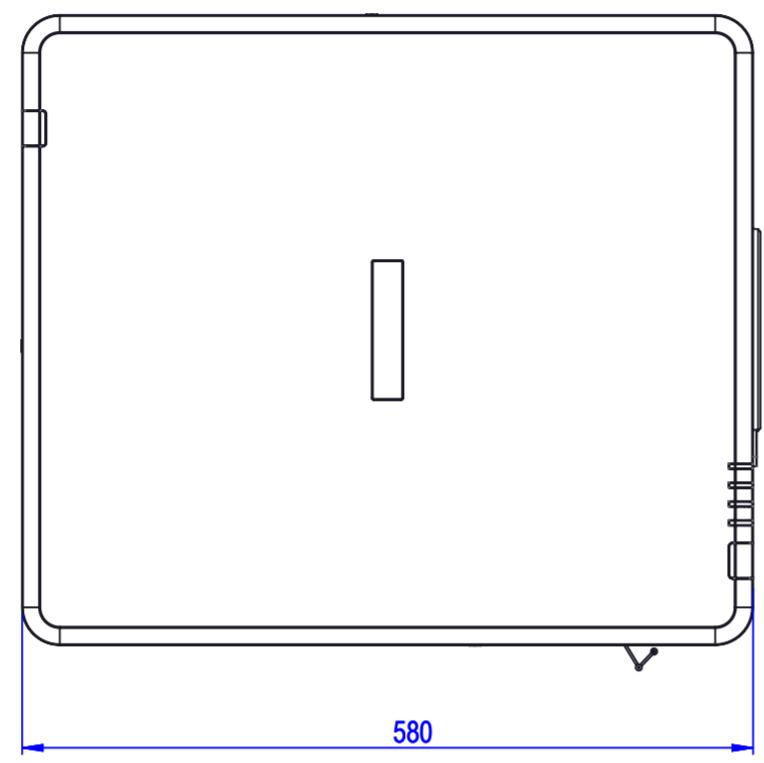

Part No.	Description
116-284	E-VISION LASER 8500 WUXGA (BLACK)
116-691	E-VISION LASER 8500 WUXGA (WHITE)
117-917	E-VISION LASER 7500 WUXGA (BLACK)
117-918	E-VISION LASER 7500 WUXGA (WHITE)

PRE REVS	ITEM	DESCRIPTION	REFER TO	No OFF	REMARKS
	7				
	6				
	5				
	4				
	3				
	2				
	1				

MATERIAL	
CODE	
FINISH	

CAD GENERATED DRAWING  
DO NOT MAKE MANUAL CHANGES

LAST CHANGE

**DATE OF ISSUE - 6-9-16**

TOLERANCES UNLESS OTHERWISE STATED	
METRIC:	1.000 ±0.01 1.00 ±0.1 1.0 ±0.2 1 ±0.4
IMPERIAL	Fractional ±1/64" Decimal ± 0.005"
ANGLES	± 0° 30'

Unless Otherwise Stated	DIMENSIONS IN MILLIMETRES
REMOVE ALL BURRS & SHARP EDGES. DO NOT SCALE DRAWING THE SURFACE TEXTURE ROUGHNESS NUMBER OF MACHINED SURFACES SHOULD BE EQUAL TO OR LESS THAN 0.8um (N6 CLA32)	
REV.	<b>A</b>
NOTE	
DRAWN	jcharley
APP.DO.	
DATE	23-03-16

FIRST USED ON	
ORIGINAL SCALE	1:6
DRAWN	jcharley
APP.ENG.	
DATE	10-11-15

**DIGITAL PROJECTION** MIDDLETON M24 1XX

TITLE: **SEE ABOVE**

COMPONENT OR DRG.No.: **SEE ABOVE**

A2-SHEET 1 OF 2

IF IN DOUBT, ASK.

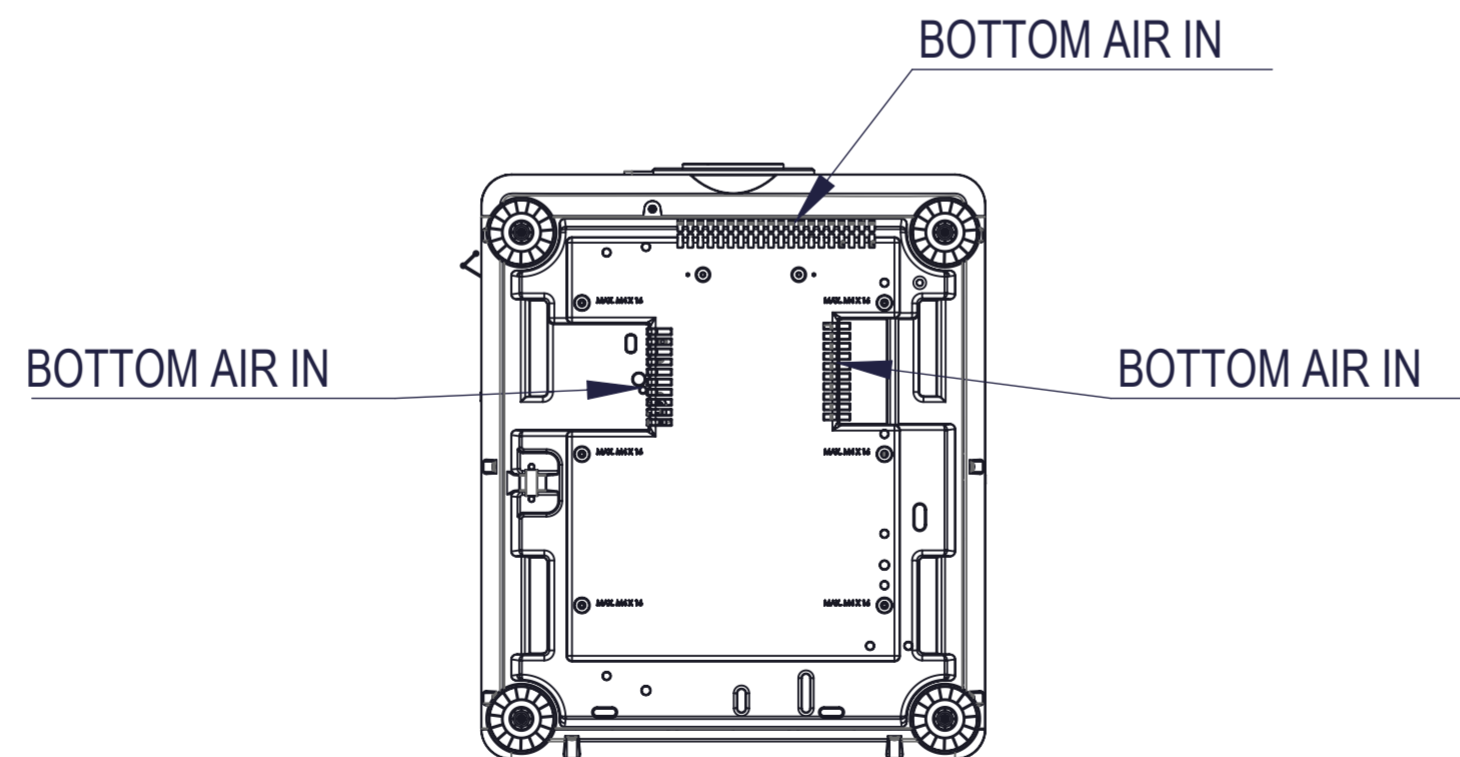
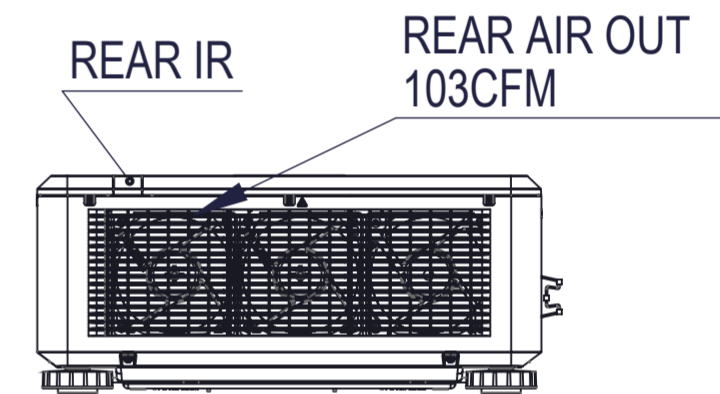
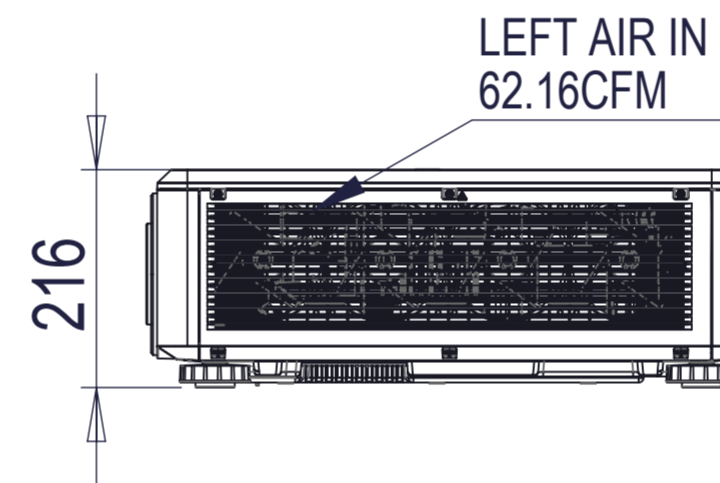
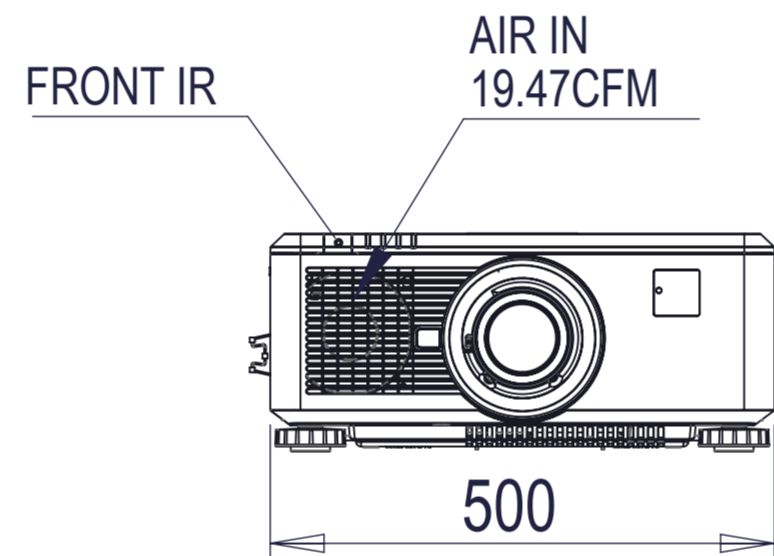
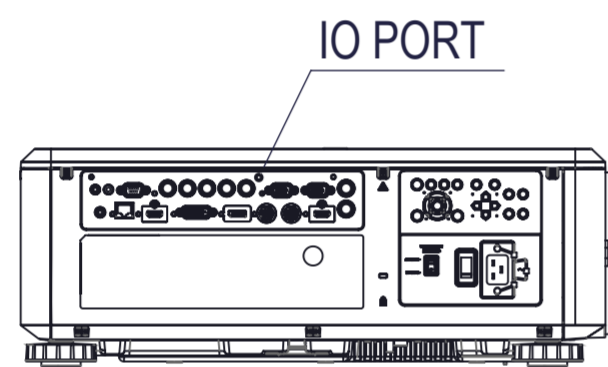
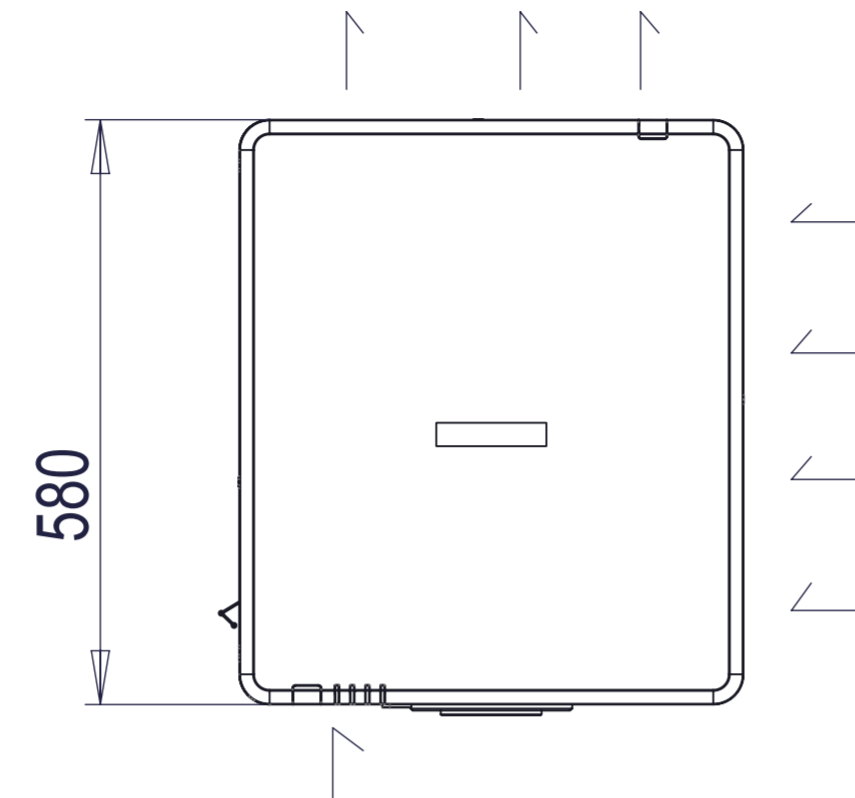

Part No.	Description
116-284	E-VISION LASER 8500 WUXGA (BLACK)
116-691	E-VISION LASER 8500 WUXGA (WHITE)
117-917	E-VISION LASER 7500 WUXGA (BLACK)
117-918	E-VISION LASER 7500 WUXGA (WHITE)

PRE REVS	ITEM	DESCRIPTION	REFER TO	No OFF	REMARKS
	7				
	6				
	5				
	4				
	3				
	2				
A	1				

MATERIAL	
CODE	
FINISH	

CAD GENERATED DRAWING  
DO NOT MAKE MANUAL CHANGES

LAST CHANGE

DATE OF ISSUE - 6-9-16

TOLERANCES UNLESS OTHERWISE STATED	
METRIC:	1.00 ±0.01 1.00 ±0.1 1.0 ±0.2 1 ±0.4
IMPERIAL:	Fractional ±1/64" Decimal ± 0.005"
ANGLES	± 0° 30'

Unless Otherwise Stated	
DIMENSIONS IN MILLIMETRES	
REMOVE ALL BURRS & SHARP EDGES. DO NOT SCALE DRAWING THE SURFACE TEXTURE ROUGHNESS NUMBER OF MACHINED SURFACES SHOULD BE EQUAL TO OR LESS THAN 0.8um (N6 CLA32)	
REV.	A
NOTE	
DRAWN	jcharnley
APP.DO.	
DATE	23-03-16

FIRST USED ON	
ORIGINAL SCALE	1:6
DRAWN	jcharnley
APP.ENG.	
DATE	10-11-15

DIGITAL PROJECTION

MIDDLETON M24 1XX

TITLE

SEE ABOVE

COMPONENT OR DRG.No.	SEE ABOVE
A2-SHEET	2 OF 2