

CP-X1200 & CP-X1250

Technical Specifications

OPTICAL	CP-X1200	CP-X1250
LCD Panel	0.99", P-Si TFT Panel x 3 with Micro Lens (P5XLA) 1024 x 768	0.99", P-Si TFT Panel x 3 with Micro Lens (P5XMLA) 1024 x 768
Resolution	f=1.7-2.4, Zoom x 1.5	f=1.7-2.4, Zoom x 1.5
Lens	310W UHB (50% Performance 2000h)	310W UHB (50% Performance 2000h)
Lamp Life	2000 Hours	2000 Hours
Brightness	3500 ANSI lumens typ. (Target) 2800 ANSI Lumens min. (P5XLA)	4500 ANSI lumens typ. (Target) 3600 ANSI Lumens min. (P5XMLA)
Contrast Ratio	500:1	800:1
Focus Distance	1.2-15.53m	1.2-15.53m
Display Size	40"-500"	40"-500"
Colour	8 Bits/colour, 16.7M colours	8 Bits/colour, 16.7M colours

COMPATIBILITY	CP-X1200	CP-X1250
Composite Video	NTSC/PAL(-BGDHI), SECAM, PAL M, N, NTSC4.43, PAL60	NTSC/PAL(-BGDHI), SECAM, PAL M, N, NTSC4.43, PAL60
Component Video	525i(480i), 525p(480p), 625i(575i), (1080i@50/60), (720p@50/60)	525i(480i), 525p(480p), 625i(575i), (1080i@50/60), (720p@50/60)
Computer	IBM Compatible VGA, SVGA, XGA, SXGA, (Smart Resizing) MAC13", MAC16", MAC19" (Pixel works Chip)	IBM Compatible VGA, SVGA, XGA, SXGA, (Smart Resizing) MAC13", MAC16", MAC19" (Pixel works Chip)
Plug & Play	DDC1/2B	DDC1/2B
Frequency Range	flt: 15-91kHz/fr: 50-120kHz	flt: 15-91kHz/fr: 50-120kHz

FEATURES	CP-X1200	CP-X1250
Keystone Correction	Keystone Automatic on Vertical only	Keystone Automatic on Vertical only
Start Up Screen	My Screen with Lock System	My Screen with Lock System
Image Control	Electrical H & V Keystone	Electrical H & V Keystone
User Controls	Picture in Picture, 11 Language Menus, Freeze Function, Magnifying, Digital Gamma Correction	Picture in Picture, 11 Language Menus, Freeze Function, Magnifying, Digital Gamma Correction
Speakers	1W x 2	1W x 2
Other	User Manual: (English, German, French, Italian, Spanish, Dutch, Norwegian, Portuguese, Chinese, Korean)	User Manual: (English, German, French, Italian, Spanish, Dutch, Norwegian, Portuguese, Chinese, Korean)

CONNECTORS	CP-X1200	CP-X1250
Computer Input	15-pin D-sub, 5 x BNC x 1 (shared with Component), 1 x M1-D	15-pin D-sub, 5 x BNC x 1 (shared with Component), 1 x M1-D
Computer Output	15-pin D-sub x 1 (from selected computer input, 15-pin D-sub or BNC)	15-pin D-sub x 1 (from selected computer input, 15-pin D-sub or BNC)
Video Input	S-Video: Jack Terminal x 1 RCA Jack Terminal x 1	S-Video: Jack Terminal x 1 Composite Video: RCA Jack Terminal x 1
Audio Input	Component Video: RCA Jack Terminal x 3 Component Share RGB1: BNC Terminal x 3	Component Video: RCA Jack Terminal x 3 Component Share RGB1: BNC Terminal x 3
Audio Output	Stereo-mini Jack Terminal x 2 for computer	Stereo-mini Jack Terminal x 2 for computer
Control	Stereo-mini Jack Terminal x 1	Stereo-mini Jack Terminal x 1
Network Interface	9-pin D-sub x 1 for RS232 RJ-45	9-pin D-sub x 1 for RS232 RJ-45

POWER	CP-X1200	CP-X1250
Power Supply	100-120V/220-240V, Auto switching	100-120V/220-240V, Auto switching
Power Consumption	240W	240W

PHYSICAL	CP-X1200	CP-X1250
Dimensions	420 x 160 x 320mm (W x H x D)	420 x 160 x 320mm (W x H x D)
Weight	7.7Kg	7.7Kg
Noise Level	39dB Normal Mode / 35dB Whisper Mode	39dB Normal Mode / 35dB Whisper Mode
Approvals	UL60950/C-UL, FCC Part 15, Class B, CE, TUV EN60950	UL60950/C-UL, FCC Part 15, Class B, CE, TUV EN60950

SUPPLIED WITH	CP-X1200	CP-X1250
	Remote Control, Batteries, RGB Cable, Video Cable for audio/video, M1-D cable (DVI and USB to M1), Power Cord, (Soft carrying case), User Manual (English, German, French, Italian, Spanish, Dutch, Norwegian, Portuguese, Chinese, Korean)	Remote Control, Batteries, RGB Cable, Video Cable for audio/video, M1-D cable (DVI and USB to M1), Power Cord, (Soft carrying case), User Manual (English, German, French, Italian, Spanish, Dutch, Norwegian, Portuguese, Chinese, Korean)

PROJECTION DISTANCE OF STANDARD LENS

Image size	Projector Distance			
	Diagonal	Width (m)	Min	Max
30" (0.76m)	0.61	0.9m (34")	1.3m (52")	
60" (1.52m)	1.22	1.8m (71")	2.7m (107")	
90" (2.29m)	1.83	2.7m (108")	4.1m (162")	
120" (3.05m)	2.44	3.7m (144")	5.5m (217")	
200" (5.08m)	4.06	6.2m (243")	9.2m (364")	
300" (7.62m)	6.10	9.3m (366")	13.9m (547")	

OPTIONAL LENSES

Screen Size (inch)	Option Lens 1 - Fixed Short		
	a Min	b 1:1	c 1:1
60	0.9m (37")	46cm (18")	-46cm (-18")
100	1.6m (63")	76cm (30")	-76cm (-30")
150	2.4m (95")	114cm (45")	-114cm (-45")
200	3.2m (128")	152cm (60")	-152cm (-60")
230	3.7m (147")	175cm (69")	-175cm (-69")

Screen Size (inch)	Option Lens 2 - Short Throw					
	Min	a Max	b 1:1	10:1	1:1	c 10:1
40	0.9m (34")	1.2m (48")	30cm (12")	61cm (24")	-30cm (-12")	0 (0")
120	2.7m (107")	3.7m (146")	91cm (36")	183cm (72")	-91cm (-36")	0 (0")
200	4.6m (180")	6.2m (245")	152cm (60")	305cm (120")	-152cm (-60")	0 (0")
300	6.9m (271")	9.3m (368")	229cm (90")	457cm (180")	-229cm (-90")	0 (0")
500	11.5m (453")	15.6m (614")	381cm (150")	762cm (300")	-381cm (-150")	0 (0")

Screen Size (inch)	Option Lens 3 - Long Throw							
	Min	a Stack	Max	b 1:1	10:1	1:1	c 10:1	10:1
40	1.8m (69")	2.4m (93")	3.3m (130")	30cm (12")	61cm (24")	-30cm (-12")	0 (0")	0 (0")
120	5.5m (216")	7.3m (287")	10.1m (398")	91cm (36")	183cm (72")	-91cm (-36")	0 (0")	0 (0")
200	9.2m (363")	12.2m (481")	16.9m (665")	152cm (60")	305cm (120")	-152cm (-60")	0 (0")	0 (0")
300	13.9m (546")	18.4m (724")	25.4m (1000")	229cm (90")	457cm (180")	-229cm (-90")	0 (0")	0 (0")
500	23.2m (913")	30.7m (1209")	42.4m (1669")	381cm (150")	762cm (300")	-381cm (-150")	0 (0")	0 (0")

Screen Size (inch)	Option Lens 4 - Long Throw							
	Min	a Stack	Max	b 1:1	10:1	1:1	c 10:1	10:1
40	3.1m (124")	4.4m (175")	5.8m (230")	30cm (12")	61cm (24")	-30cm (-12")	0 (0")	0 (0")
120	9.7m (382")	13.6m (535")	17.8m (701")	91cm (36")	183cm (72")	-91cm (-36")	0 (0")	0 (0")
200	16.2m (640")	22.8m (896")	29.8m (1172")	152cm (60")	305cm (120")	-152cm (-60")	0 (0")	0 (0")
300	24.4m (962")	34.2m (1346")	44.7m (1760")	229cm (90")	457cm (180")	-229cm (-90")	0 (0")	0 (0")
500	40.8m (1607")	57.1m (2248")	74.8m (2937")	381cm (150")	762cm (300")	-381cm (-150")	0 (0")	0 (0")

HITACHI

Inspire the Next

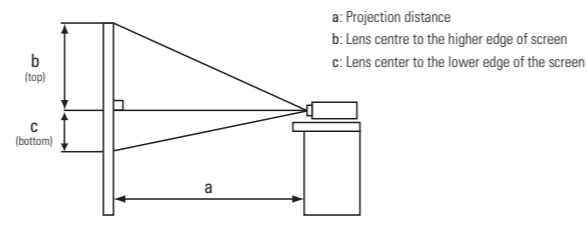
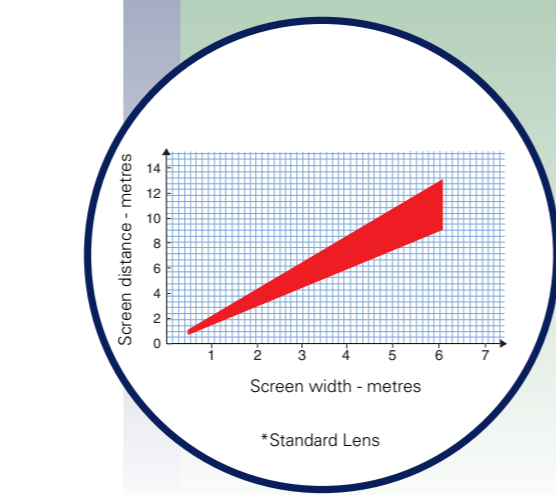
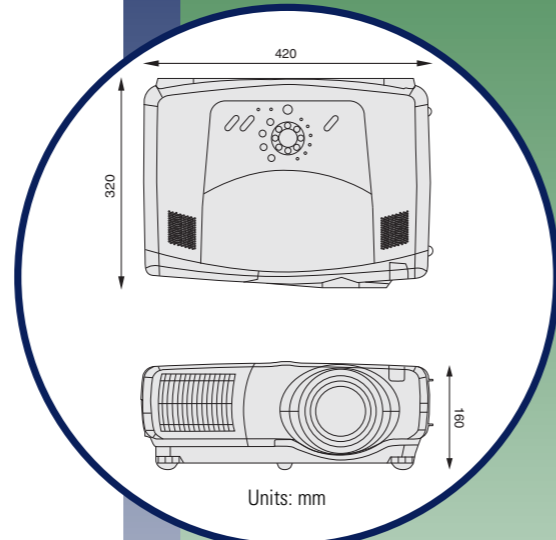

computermiete.de

Dieses Produkt können Sie mieten bei
computermiete.de
Tel. +49 - (0)721-93244-10
E-Mail: juergen.wagner@computermiete.de

CP-X1250

CP-X1200



CP-X1250 XGA
4500 ANSI Lumens



CP-X1200 XGA
3500 ANSI Lumens

HITACHI

Inspire the Next

www.hitachidigitalmedia.com

HITACHI DIGITAL MEDIA, Hitachi Europe Ltd, Whitebrook Park, Lower Cookham Road, Maidenhead, Berkshire SL6 8YA

Tel: 01628 585 000 Fax: 01628 585 500 www.hitachidigitalmedia.com

The specification above and photography is for reference only and may be subject to change.

CP-X1250/CP-X1200

CP-X1250/CP-X1200 features

- 4500 ANSI Lumens (CP-X1250)/3500 ANSI Lumens (CP-X1200)
- Full Connectivity
- Vertical Lens Shift System
- Horizontal and Vertical Keystone Correction
- My Screen Option with Lock System
- 1.5x Zoom Lens
- Progressive Scan for smooth, flicker-free pictures

With an astounding output of 4500 ANSI Lumens (3500 ANSI Lumens for CP-X1200), a 0.99" liquid crystal panel plus a UHB 310W lamp, these projectors give astonishing brightness and will project clearly visible images even in brightly lit rooms.

They are ideal for medium to large venues and the flexibility of the zoom lens and Vertical Lens Shift System gives you the freedom to choose exactly where you want to install the projector. XGA resolution means that presentations containing fine detail such as spreadsheets and diagrams are clear and sharp, whilst the 800:1 contrast ratio on the CP-X1250 (500:1 on the CP-X1200) delivers superb graphics.

Advanced features enhance presentation quality and make delivery even easier. Other features include Horizontal and Vertical Keystone correction, which corrects keystone distortion, whilst the My Screen feature allows an image to be displayed at switch on before the presentation begins. With full connectivity the CP-X1250 and CP-X1200 models feature the usual DVI and component terminals, with the addition of BNC terminals.

Advanced User Features

The CP-X1250 and CP-X1200 models boast a variety of features, which offer outstanding brightness, picture quality, and convenience for all types of presentations.

Vertical Lens Shift System

If you are unable to place the projector directly in front of the screen then use this feature to give you installation freedom. With a 10:0 to 1:1 lens shift capability, the CP-X1250 and CP-X1200 allows you to move the picture vertically a distance equal to one half of the picture, whilst still throwing a perfectly aligned image. This feature can also be controlled by remote control and easily adjusted, even when the projector is ceiling mounted.

High Brightness

A high, 800:1 (CP-X1250) and 500:1 (CP-X1200) contrast ratio enables these projectors to deliver images with unbelievable impact, retrieving and displaying the darkest shades of black and the brightest whites, for a stunning viewing experience.

Convenient Ceiling Installation

Both of these projectors have a lamp replacement panel on the top, which makes it easier to change the lamp when the unit is suspended from the ceiling. Cable connection is stable due to the BNC terminal and the projector can be controlled from far away using the wireless remote control.

My Screen Function with Lock System

The new My Screen feature allows the user to store an image such as a company logo or a product picture in the projector's non-volatile memory. This image is then displayed immediately when the projector is switched on, even before any input sources are connected, providing a more professional start to a presentation. The Lock System ensures that anything stored in the My Screen function is not accidentally overwritten.

1.5x Zoom Lens

The CP-X1250 and CP-X1200 projectors both feature a 1.5x zoom lens as standard, which can be used at distances from 3.0 to 4.6m to project a 100" screen. This allows greater flexibility in positioning the projector where space is limited. The electronically powered zoom, focus and lens shift can all be adjusted via the remote control.

Optional lenses for all uses

Four different optional lenses are available, suitable for a wide range of applications. This allows you to position the projectors in the best position suited to the environment, from small to large venues. And as the lenses are bayonet types, they are easy to replace.

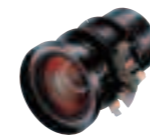

Fixed Short
(FL-501)



Short Throw
(SL-502)



Long Throw
(LL-503)



Long Throw
(LL-504)

Projection Distance Chart

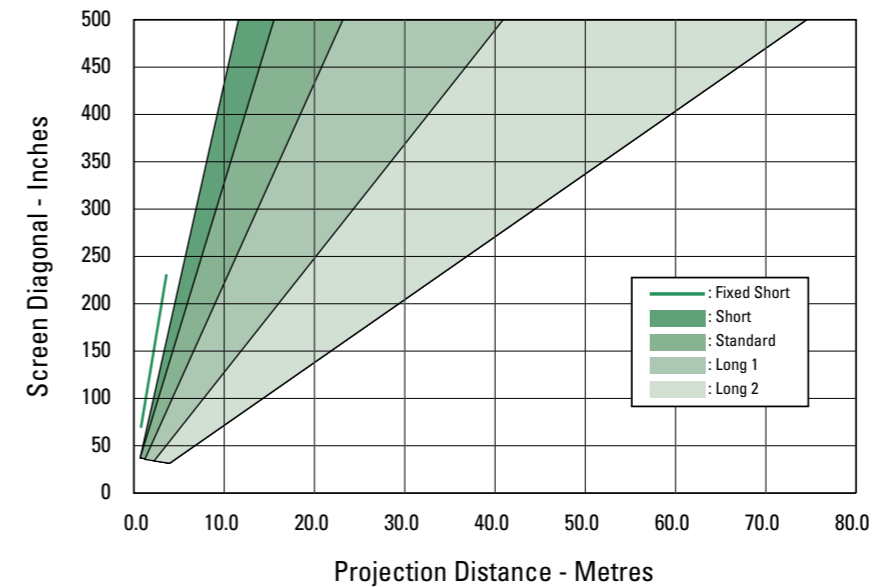

Horizontal and Vertical Keystone Correction

Setting up is both easier and more flexible thanks to integrated horizontal and vertical keystone correction, accessed directly via a single button on the unit's control panel. This feature means that the projector can be set off to the right or left of the screen and correction can be applied to remove any image distortion.

Motion Adaptive Progressive IC

Hitachi's unique Motion Adaptive Progressive integrated chip delivers 480-line, progressively scanned video images, which are smoother and more detailed than traditional interlaced video images. This ensures no visible scan lines and perfect pictures every time.

Multiple Inputs

Both the CP-X1250 and CP-X1200 offer virtually every input connection required to accommodate today's media sources. Video inputs cater for composite, S-Video and component video formats, all with stereo audio. On the computer side there are two analogue RGB inputs and in addition to the usual DVI and Component terminals, these models have a new BNC terminal and also a D-sub 9-pin adapter.

Port Exhaust Fan

Air is expelled from the front of the projector, so that viewers, who will typically be seated either behind or to the side of the projector, won't be affected by a current of hot air.



For business presentations

The CP-X1250 can be used for a wide range of effective presentations in any space from small meeting rooms to large conference rooms.



Conference Halls

With exceptionally high brightness, the CP-X1250 can project high quality images, even in a large hall.



For academic uses

Projectors in various classrooms and lecture theatres will provide clear, sharp and detailed on-screen images.